



2015 GMC Yukon Billet Grille Insert

TOOLS REQUIRED:

Flat Head Screwdriver
Long Flat Head Screwdriver
Phillips Screwdriver
7mm Socket
10mm Socket
Ratchet & Extensions
3/16 Drill Bit
Power Drill
Cutting Wheel or Saw
Locking Pliers

PARTS LIST

(4) #10 1" Screws
(4) #10 Flat Nuts
(4) #8 3/4" Screws
(4) #8 Flat Nuts
(2) Nylon Clips
(2) Rectangle Spacers
(2) 1" Fender Washers
(2) 6-32 Nylock Nuts
(2) 1-1/2 J Hooks

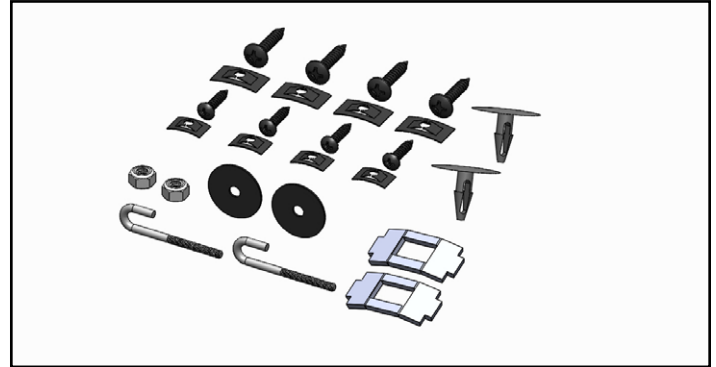

PLEASE READ AND UNDERSTAND ALL INSTRUCTIONS BEFORE INSTALLATION. Auto makers offer varied models to each vehicle and occasionally manufacture more than one body style of the same model. To assure your part is correct; our tech department can be contacted at tech@trexbillet.com to verify fitment or assist with tech questions. All other inquires can be directed to info@trexbillet.com. In the event you do not have internet access please call 1-800-287-5900.

Step 1

Open hood and remove the 6 plastic push clips securing the plastic radiator shroud to the radiator core.

Carefully use a flat head screwdriver to release the clip up, you can now remove the clips.

Once all clips have been removed the plastic radiator shroud can be removed. (Fig 1)



Step 2

Using your 10mm socket and ratchet remove the six (6) 10mm bolts securing the upper grille assembly to the radiator support. (Fig 2)



Step 3

Move to the sides of the front bumper and remove the six (6) 7mm bolts securing the lower bumper cover to the inner fender liner and fender.

Turning the wheels will allow with additional room to remove the bolts.

Repeat on opposite side of bumper. (Fig 3)



Step 4

Under the front bumper remove the eight (8) 10mm bolts securing the bottom of the bumper to the chassis.

Two in the center and three (3) on each side.

Finally detach the lower wiring harness clips securing the lower wiring harness to the bumper. (Fig 4)

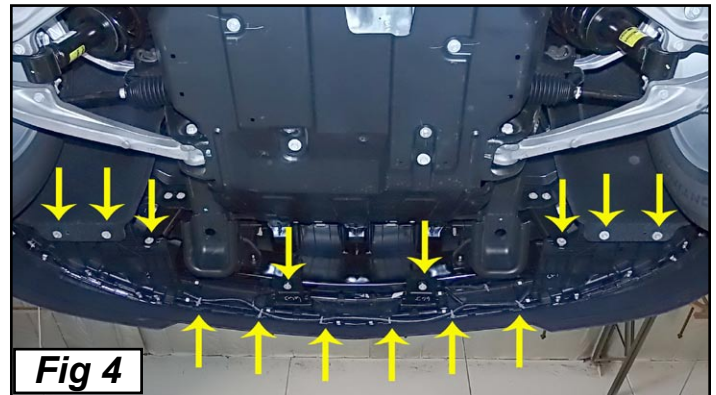

Step 5

Return to the top of the grille assembly, gently pull back on the top of the assembly to access the rear of the grille assembly.

Disconnect the fog light wiring harness, then remove the two (2) 10mm securing the bumper to the chassis.

Finally with your flat head screwdriver to depress the two lower tabs securing the bumper to the chassis. (Fig 5)

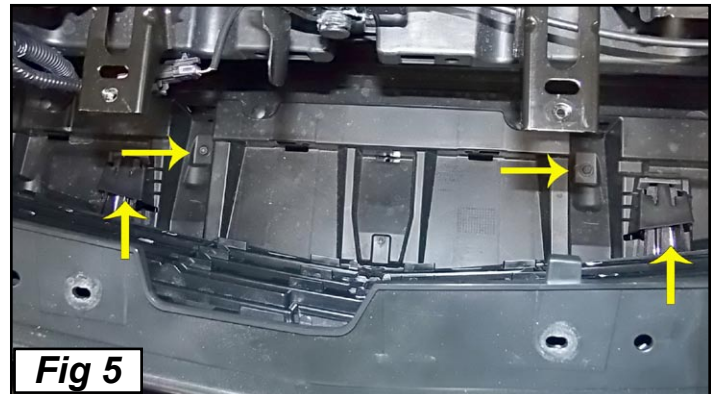

Step 6

Firmly grasp the side of the bumper by the fender and carefully detach the end of the bumper from its retaining clip. Repeat on opposite side.

With the help of an assistant. The front bumper can now be removed by pulling the entire bumper/ grill assembly away from the front of the vehicle.

Place Grille/ Bumper assembly face down on a soft surface. (Fig 6)



Step 7

Remove the plastic rivet located on the corners of the grille assembly securing it to the bumper.

Discard clips. (Fig 7)



Step 8

Using a pair of pliers detach the 14 tabs that secure the grille assembly to the factory bumper.

Detach the factory wiring harness clipped to the bumper/ grille assembly.

Separate the grille assembly from the bumper. (Fig 8)



Step 9

Place the grille assembly face down. Trace a line along the edge of the inner grille assembly as shown. (Fig 9)

Using a cutting wheel or saw carefully cut along the line traced (Fig 9A). Remove and discard inner grille assembly.

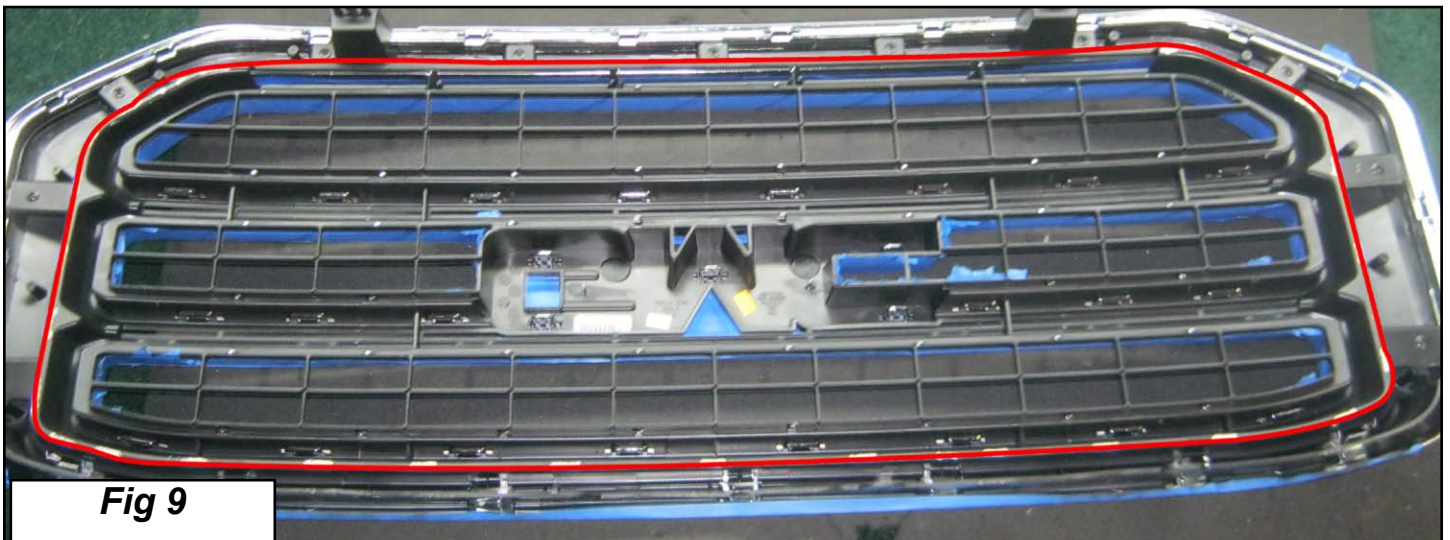

Step 10

Place the new grille inset into the open grille assembly from front in. Line up the mounting tabs to outer edge of the factory grille shell.

Drill a 3/16 hole into the factory grille shell using the mounting hole as a pilot hole.

Use locking pliers to keep the tab secured to the grille as you drill. (Fig 10)



Fig 10

Step 11

Secure the (8) screws to the grille assembly with the included screws and flat nuts.

The top four (4) use the smaller #8 screws and flat nuts.

The lower four (4) use the larger #10 screws and flat nuts. (Fig 11)



Fig 11

Step 12

Your installation is now complete. Reattach the grille/ bumper assembly back to the vehicle in reverse order of removal.

Use the included plastic rivets to replace the rivets removed in step 7.

If you would wish to reuse your factory emblem please see page 5 for removal from the factory grille.

Make sure you reconnect all disconnected wiring harness and reattach all clips and screws. (Fig 12)



Fig 12

20169/ 20169B
2015 GMC Yukon



20169/ 20169B
2015 GMC Yukon

2015 GMC Yukon OEM Emblem Installation Kit

TOOLS REQUIRED:

10mm Wrench
Locking Pliers

NOTE: Factory Emblem is not supplied with grille kit.

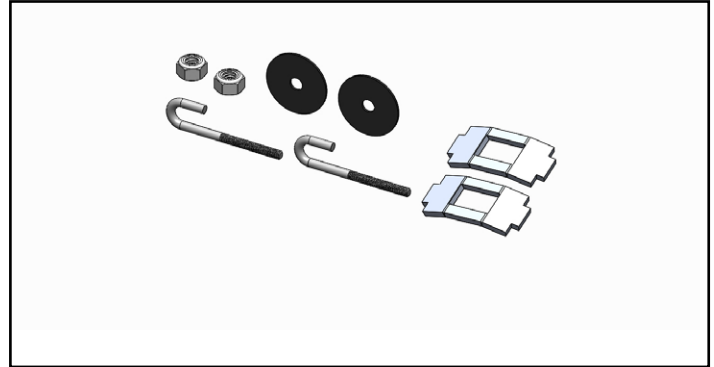

Step 1

Remove the OE emblem from the factory grille by depressing the tabs securing the emblem to the grille. (Fig 1)



Step 2

Break off the center tab from the back of the emblem. (Fig 2)



20169/ 20169B
2015 GMC Yukon



20169/ 20169B
2015 GMC Yukon

Step 3

Center the emblem in your new grille. From the back slide the two J hooks into the center mounting tabs of the emblem. (Fig 3)



Step 4

Secure emblem to the grille with the included spacer, flat washer and nuts. (Fig 4)

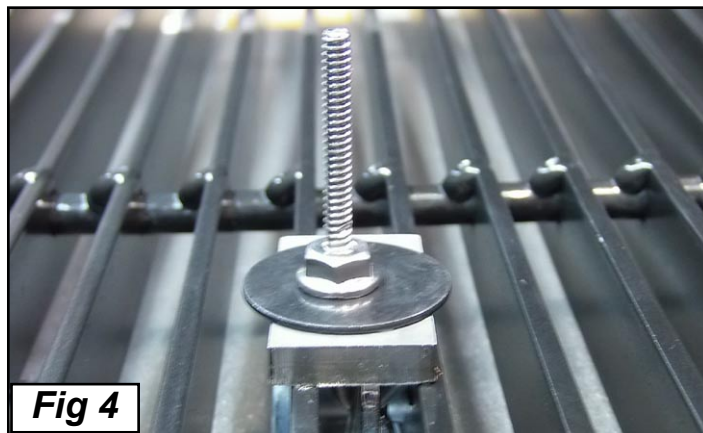

Step 5

Your emblem installation is now complete. (Fig 5)

